

**| MAKE**  
**YOUR JOB**  
**EASIER!**

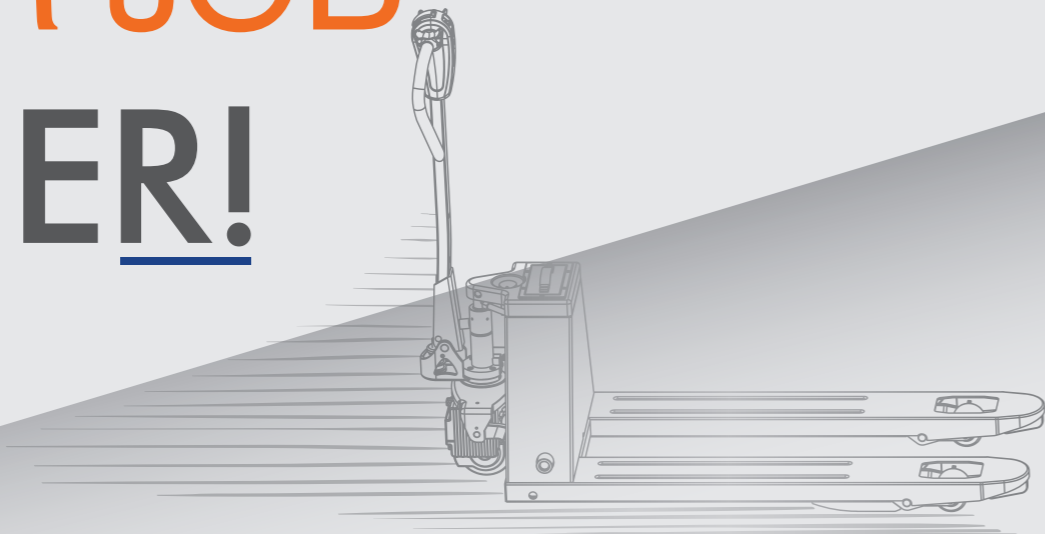

## **ERT20H & PPT20H**

Ηλεκτρικά & Ημι-ηλεκτρικά  
παλετοφόρα

# CHARACTERISTICS

Closer look into

# SMART FUNCTION

Notes: "★" – Available with different options.

**Horn**

**Emergency reverse button**

**Forward/reverse butterfly switch**

**Lifting/ Lowering**

**LCD Screen**

- Battery indicator with hour meter
- Error code display
- Recharge Alert

**Multi-function Handle (Full Electric)**

**Multi-function Ergonomic Handle (Semi-electric)**

**Lithium battery pack**

**BUILT TO WORK 24/7 FULL-ELECTRIC**

**★ Tandem/Single PU wheel**

**Integral Forks**  
Ideal design for closed pallet(single load wheel)

**★ Protection cover**

**★ Manual Lifting/Lowering(Quick Lift)**

**Electric Lifting/Lowering**

**★ Fast Charger option(2hrs)**

**SMART FUNCTION 01**

**Turtle Speed**  
Horn Remains Pressed & Forward 2 times

**SMART FUNCTION 02**

**Up-Right Drive**  
Reverse Button & Forward Throttle Remain Pressed, Power On

**SMART FUNCTION 03**

**Engineering Mode (Brake Release)**  
Horn Remains Pressed, Power On

- ⚠ In up-right drive mode, vehicle will move when handle is operated at any position. Please avoid misoperation.
- ⚠ Brake release mode is only for emergencies, not allowed for vehicle with normal conditions.

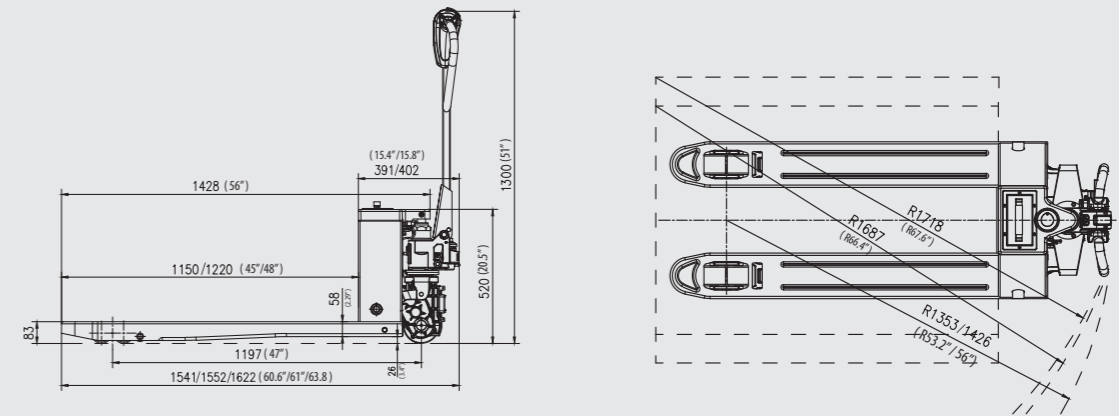

MODEL		PPT20H	EPT15H	EPT20H	EPT15H-65L	PPT44H	EPT33H	EPT44H	EPT33H-2.6L		
<b>CHARACTERISTICS</b>											
1.1 Capacity	kg	2000	1500	2000	1500	lb	4400	3300	4400	3300	
1.2 Load center	mm	600	600	600	600	in	23.6	23.6	23.6	23.6	
1.3 Overall fork width	mm	550/685	520/550/685	550/685	550/685	in	21.6/27	20.5/21.6/27	21.6/27	21.6/27	
1.4 Fork length	mm	1150/1220	1150/1220	1150/1220	1150/1220	in	45/48	45/48	45/48	45/48	
1.5 Overall length	mm	1552/1622	1552/1622	1552/1622	1552/1622	in	61/63.8	61/63.8	61/63.8	61/63.8	
1.6 Lowered height of fork	mm	82±2	82±2	82±2	65±2	in	3.2±0.8	3.2±0.8	3.2±0.8	2.6±0.8	
1.7 Max height of fork	mm	197	197	197	165	in	7.8	7.8	7.8	6.5	
1.8 Overall height (with tiller)	mm	1276	1276	1276	1250	in	50	50	50	49	
1.9 Rear body width	mm	550/685	520/550/685	550/685	550/685	in	21.6/27	20.5/21.6/27	21.6/27	21.6/27	
1.10 Minimum turning radius	mm	1353/1426	1353/1426	1353/1426	1353/1426	in	53.2/56	53.2/56	53.2/56	53.2/56	
<b>PERFORMANCE</b>											
2.1 Max.Traveling speed	laden	km/h	4	4	4	4	mph	2.5	2.5	2.5	2.5
	unladen	km/h	5	5	5	5	mph	3.1	3.1	3.1	3.1
2.2 Gradeability	laden	%	6	6	6	6	%	6	6	6	6
	unladen	%	20	20	20	20	%	20	20	20	20
2.3 Traveling	kw	DC 1.0 Brushless	DC 0.75 Brushless	DC 1.0 Brushless	DC 0.75 Brushless	kw	DC 1.0 Brushless	DC 0.75 Brushless	DC 1.0 Brushless	DC 0.75 Brushless	
2.4 Lifting	kw	Hydraulic	DC 0.8	DC 0.8	DC 0.8	kw	Hydraulic	DC 0.8	DC 0.8	DC 0.8	
<b>BATTERY</b>											
4.1 Voltage	V	48	48	48	48	V	48	48	48	48	
4.2 Capacity/type	Ah	10/15 Ah Lithium	10/15 Ah Lithium	10/15 Ah Lithium	10/15 Ah Lithium	Ah	10/15 Ah Lithium	10/15 Ah Lithium	10/15 Ah Lithium	10/15 Ah Lithium	
<b>BRAKE TYPE</b>											
5.1 Travel brake		Regenerate	Regenerate	Regenerate	Regenerate		Regenerate	Regenerate	Regenerate	Regenerate	
5.2 Brake		Electromagnetic	Electromagnetic	Electromagnetic	Electromagnetic		Electromagnetic	Electromagnetic	Electromagnetic	Electromagnetic	
<b>CONTROLLER</b>											
6.1 Controller		STAXXB1503	STAXXB1503	STAXXB1503	STAXXB1503		STAXXB1503	STAXXB1503	STAXXB1503	STAXXB1503	